

User Manual

Flextight X5 / X1

English – v/1.3



H A S S E L B L A D

Table of contents

Warnings and Restrictions	4
System Requirements	4
Parts and components	5
Front panel	5
Back panel and cutaway view	6
Setting up the Scanner	7
Environmental Requirements	
Electrical Requirements	
Installation Procedure, FireWire Interface	
Operating Instructions	9
Resolutions	10
True Resolutions	
Calibrating the Scanner	11
Focus Calibration	12
White Calibration for Reflectives	13
The Light Tubes	14
Cleaning the External Surface of the Scanner	16
Disposal	16
Technical Specifications	16
FCC Notice	17
CE - Declaration of conformity	18
Flextight X1	18
Flextight X5	19

The Flextight X1 and the Flextight X5 satisfy the demand for image quality and speed requirements from professional photographers and production environments alike.

Developed around Hasselblad's patented virtual drum design and flexible magnetic holder and incorporating a 3x8000 optic CCD sensor and a Linos (Rodenstock) lens, both scanners are fast, easy-to-use and offer unparalleled image quality. They also feature a new time-saving facility – an 'Auto Scan' button, which with one press automatically delivers a superb, high resolution scan.

The Flextight X1 scans 35mm originals at a maximum non-interpolated optical resolution of 6300 dpi at a maximum speed of 60MB per minute while the Flextight X5 scans 35mm originals at up to 8000 dpi and at 300MB per minute, making it the world's fastest, high-end scanner. The Flextight X5 also has an A4 reflective scanning option, can take a batch or a slide feeder and incorporates Hasselblad's active cooling capability, where an electronic device is placed directly on the CCD to cool it down and prevent an increase in electrical noise.

As with all Hasselblad scanners, the Flextight X1 and Flextight X5 offer outstanding sharpness and image quality and are designed to bring out the finest details and the full tonal range from the professional photographer's negatives or transparencies. Both Flextight models offer a maximum non-interpolated, optical resolution of 3200 dpi in true 8 or 16 bit colour from 60mm originals and 2040 dpi from 4" x 5" originals, both positive and negative. The two scanners also provide automatic frame detection, batch scanning, automatic focus and calibration, hardware (Flextight X5 only) and software-based Auto Dust

Removal and both utilize Hasselblad's unique FlexColor software and 3F – Flexible File Format. These features produce a digital data management system to provide users with a fully integrated workflow solution that spans from image capture to output. Both scanners are PC and Mac compatible using a FireWire interface.

The Flextight scanners also include a full selection of holders for mounting all of the most common original formats without requiring gel, tape or glass plates and include a full selection of the most common negative film set-up profiles. Support for special formats, such as panoramas, can also be customised and supplied by Hasselblad. The scanners use glass-free original holders that 'flex' the original during the scanning process to form a completely straight line that places nothing between the original and the electronic image sensor. This ensures that the quality remains at its highest level without glass distortions and other unwanted artifacts.

For the optimum in investment security, a Flextight X1 can be modified and upgraded to a Flextight X5 model at a later date for approximately the difference in price between the two scanners. Either way you can rest assured you have made the right choice.

***The supreme Hasselblad potential is there,
it's up to you to exploit it!***

Warnings and restrictions

- Read all of the included documentation before attempting to install and use the scanner.
- Do not touch the originals and/or the original holder while scanning.
- Do not start scanning or previewing until an original holder with an original has been mounted.
- The original holder is only to be mounted or removed when the drum is in the load position.
- When you turn on the scanner, the drum will roll to the load position, if it is not there already. Do not touch the scanner while the drum is rotating.
- Do not place your fingers or any other object into the scanner while it is connected to power.
- Before servicing or opening the scanner, the power supply must be disconnected from the mains (unplugged). It is not sufficient simply to press the on/off button.
- Install the scanner in a location where children can not get to it. It contains small openings and moving parts that can cause injury.

System requirements

Below are the basic hardware requirements for the PC or Macintosh system to which the scanner is to be connected. For information about the processor, operating system, RAM and harddisk requirements please refer to the “Software Reference” manual, that comes with the FlexColor software.

- Screen resolution of minimum 800 x 600 pixels with true colors (24-bits).
- Mouse or other pointing device.
- FireWire interface.

Preventive maintenance

All Flextight scanners should be serviced every 25,000 scans or every 12 months, whichever comes first. If a Feeder is mounted, the recommended number of scans is 15,000 provided that the feeder is mounted for all scans. Please note that previews are also counted as scans.

Newer Flextight scanners have a counter installed so that the number of scans can be monitored from FlexColor. Please refer to the FlexColor manual to learn more about monitoring the number of scans.

Failures or faults originating from lack of service and/or daily maintenance are not covered by the factory warranty.

Parts and components – front panel

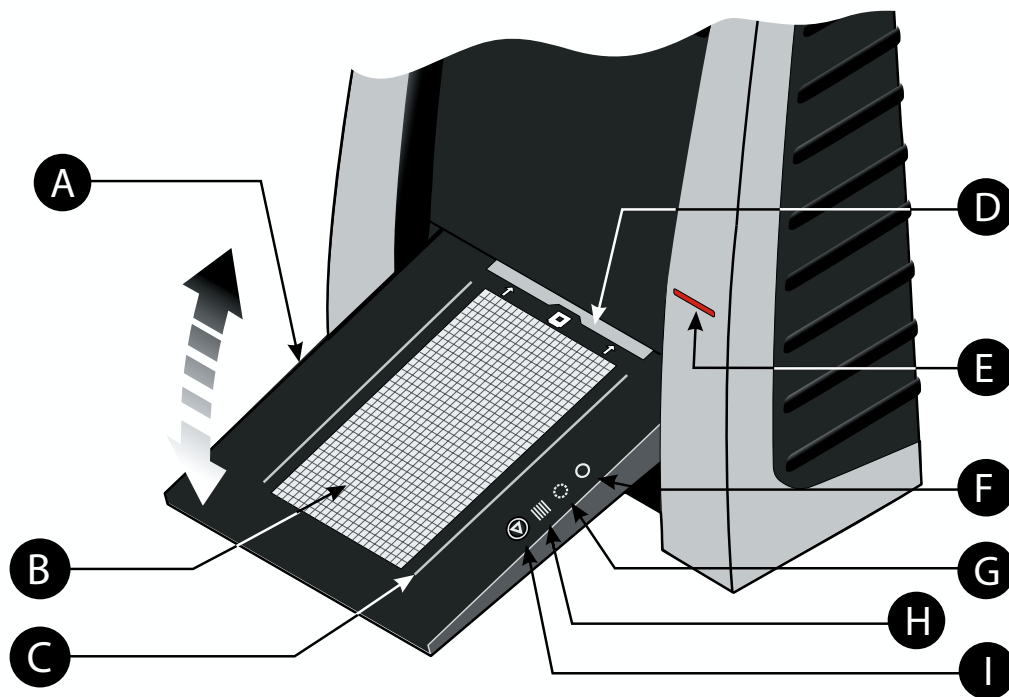

A Feed table

This must be in the lower position for normal scanning. When scanner is not in use you can return it to closed position to protect it from dust etc. Adjust to horizontal position when using the 35 mm slide mount holder.

B Light table

For viewing originals. The grid helps you to align your transparent originals.

C Transparency holder guide

Two rails that guide all the transparency holders and keep them in a straight orientation.

D Original holder clasp

All original holders slide into a slot here and are held in place by a magnetic clasp.

E Power switch

Button to turn the unit on/off.

F Power indicator (Green)

Remains lit when ready to scan. Flashes when first installed to indicate that firmware must be loaded (it will be loaded automatically when you run FlexColor).

G Motor drive indicator (Yellow)

Lights when the scanner is repositioning the optics to scan in a new format or when drum is repositioning.

H Scan indicator (Red)

Lights when scanning. Do not touch the scanner while this indicator is lit. If the light is flashing when not scanning, then an error has occurred - please contact your Flextight dealer for assistance.

I Start/stop scan button

With this button you can initiate a 3F scan. Parameters are set according to your 3F scan setup. The button will also stop any normal scan process.

Parts and components – cutaway view

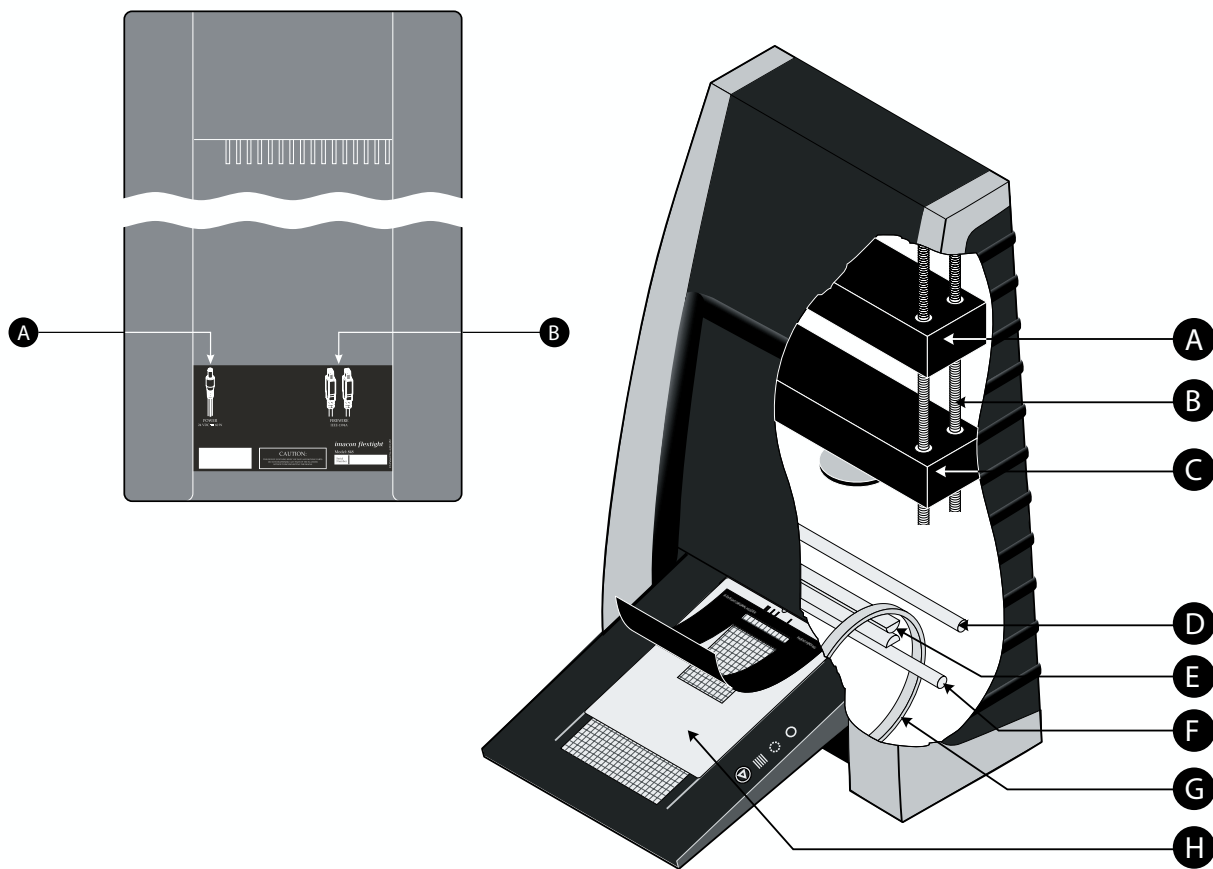

A Power cable socket

Connect the power cable into this socket.

B FireWire interface sockets

Socket for FireWire cable (max. 6 m) for computer connection. The second socket allows connection to another device (hard disk, printer etc.) in the FireWire chain.

C CCD housing

Movable platform holding the CCD sensor.

D Spindle

For positioning of the CCD housing and optics housing for the appropriate resolution and original size.

E Optics housing

Movable platform holding the optics that focuses the image of the original on the CCD-sensor.

F Upper light source

Illuminates reflective originals. FlexTigh X5 only.

G Prism-module

Focuses the light from various angles and thereby removes or heavily reduces dust and scratches in the scanned image. FlexTigh X5 only.

H Lower light source

Illuminates transparent originals.

I Drum

Rotates the original into the scanner and transports it past the optical scan line.

J Original holder

In this case, a transparency holder is shown in the mounted position and with the retaining flap held open.

Setting up the scanner

Environmental requirements

Set up the scanner in a location that fulfils the following requirements:

- Keep the scanner away from sources of heat, such as direct sunlight or a radiator. Warm temperatures will degrade the quality of your scans - for best results, work in a cool environment.
- The scanner must be operated away from sources of strong electromagnetic interference. Although the scanner complies with all regulations governing electromagnetic immunity and every reasonable step has been taken to make the unit immune to electromagnetic interference, it is still a precision electronic device and therefore strong radio waves could interfere with your scans.
- The surface on which the scanner is placed must be stable and free from vibrations. If the scanner is shaken or moved while scanning, your results may be affected.
- If the scanner has been in a colder environment (e.g. outside or in storage) just before set up in a warmer room, then wait about two hours before using it - otherwise, condensation may form, which will prevent the scanner from operating correctly.
- Avoid using the scanner in areas where there is a high level of dust.

Electrical requirements

The Flextight power supply requires a mains voltage of between 100 and 240 V AC at a frequency of 50 to 60 Hz. This is within the normal wall-socket power standards of most countries. Do not attempt to use Flextight with any power source outside the specified range. The scanner and all devices attached to the scanner (computer, monitor, FireWire devices, etc.) must be grounded (i.e. use a three-point electrical connection). Note that the power supply may emit a low hissing sound when plugged in but not connected to the scanner. This is normal and will not damage the power supply or scanner.

Installation procedure – FireWire interface

Proceed as follows:

1. Place the scanner on a table near your computer with the front facing away from you. Make sure that the location you choose meets all environmental and electrical requirements.
2. When using a FireWire interface connection, it is not necessary to switch off your computer and other connected units. Connect a FireWire cable from one of the FireWire connectors on your scanner (see Back Panel on page 6) to either the computer's FireWire connector or to a free FireWire connector on any other FireWire device already connected to your computer.
3. Connect the round connector from your power supply to the power supply socket on the back of the scanner (see Back Panel on page 6).
IMPORTANT: Make sure that the wall socket you are planning to use meets the electrical requirements outlined earlier. Plug the Flextight X1 / X5 power supply into a wall socket. Note that the power supply may emit a low buzzing sound when plugged in. This is normal and will not damage the power supply or scanner.
4. Turn the scanner around so that the front is facing you.
5. Your system is assembled. Turn on your computer and install the FlexColor image scanning software.

For horizontal positioning lift the table free from the hinges and push.

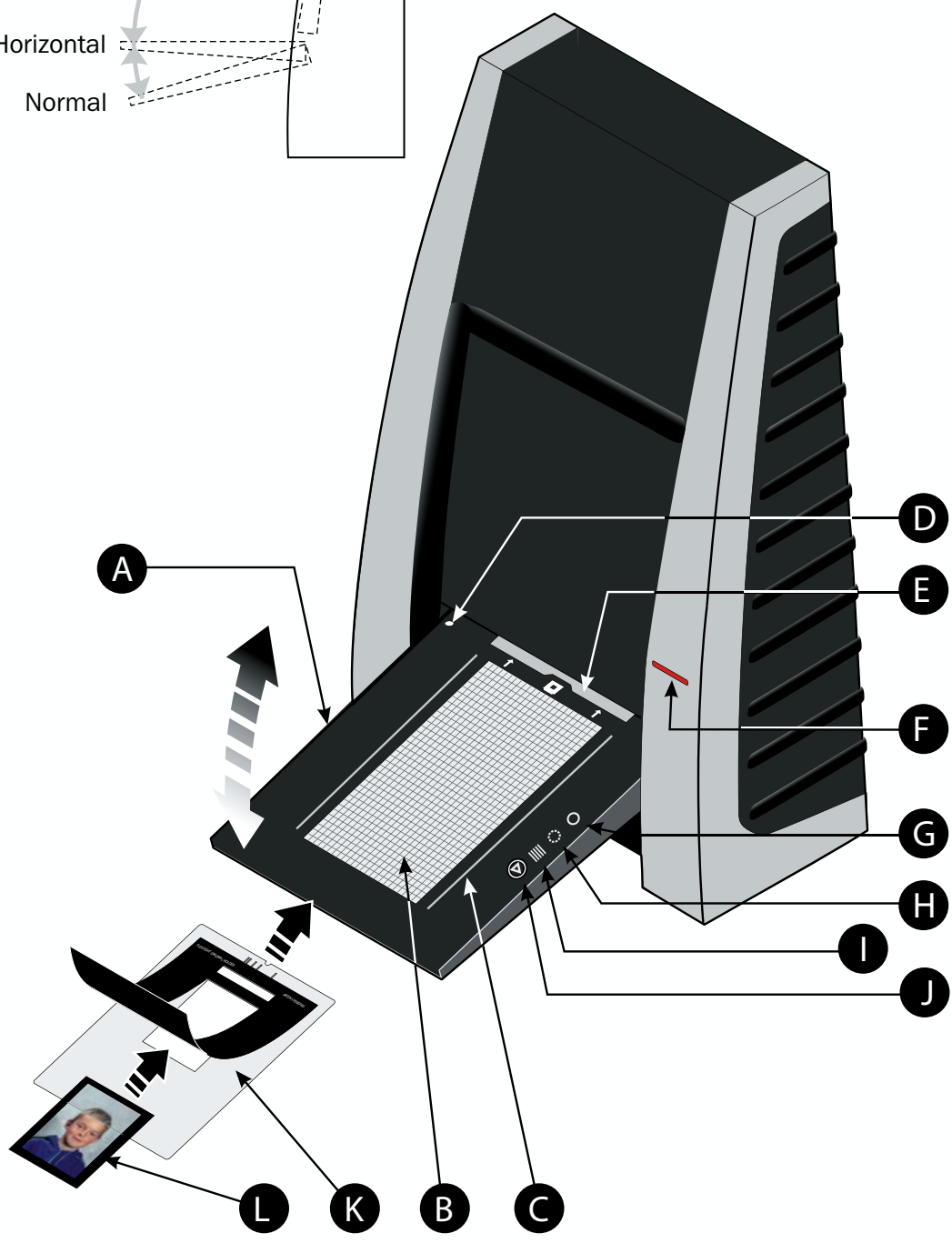
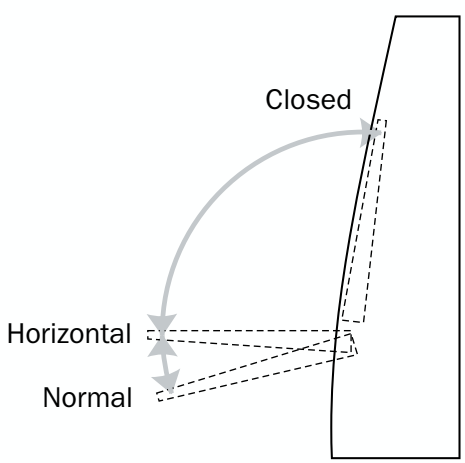

Operating instructions

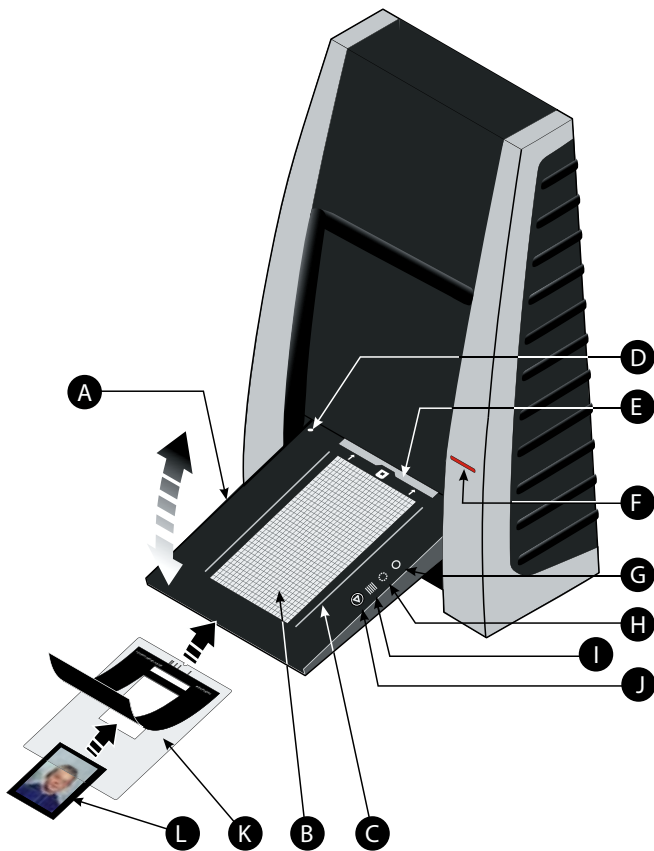

1. It is assumed that the scanner and FlexColor software have been properly installed.
2. If not already done, lower the feed table **A** to normal position.
3. Press the red power button **F** on the front of the scanner to switch it on. The green light **G** starts flashing. This means that no firmware has been downloaded yet. It will be downloaded automatically later when you first run the FlexColor program.
4. Turn on your computer and start the FlexColor program. The green light **G** will stop flashing indicating that firmware has been downloaded to the scanner.
5. Select the original holder **K** that matches your original:
 - For transparencies, choose one of the holders that has a square hole in it. The original must completely fill the hole with no edges showing. Also, no edges of the original must extend past the outer edges of the holder.
 - For reflectives, select the large A4/letter-size holder with the clear plastic layer. The feed table **A** must be in normal position.
 - For 35 mm slide frames use the optional 35 mm slide mount holder. The feed table **A** must be adjusted to horizontal position (see diagram). This is obtained by lifting the table slightly upwards while pushing it gently into the scanner.

NOTE! Each original holder has its own unique identification code (a combination of small rectangular holes at the holder's leading edge). These codes, combined with the scanner's ability to detect the feed table position, ensure that the scanner will not operate unless the feed table position matches the selected original holder.

6. Place the original holder **K** with the slotted tab facing into the scanner. For transparencies, the flexible magnetic retaining flap must face upwards. For reflectives, the clear plastic sheet must face upwards. Make sure that the original holder fits between the appropriate guides **C** or **D** on both sides of the light table.
7. Slide the holder gently into the slot **E** at the top of the feed table. It will slip about ½ cm (¼ inch) into it. Do not press too hard. It slips in very easily and is held in place by a magnetic clasp. To remove the holder, simply pull it gently backwards.
8. Lift the retaining flap of the original holder and place your original **L** as follows:
 - For transparencies, place your original with the emulsion side down. The original must completely fill the hole with no edges showing and with a minimum overlap of 2 mm along each edge. Also, no edges of the original must extend past the outer edges of the holder. Use the grid on the light table **B** to help line up the image.
 - For reflectives (Flextight X5 only), make sure that no part of the original extends past the edge of the holder. Use the dotted

lines printed on the holder to line up the image. Handle the clear plastic layer only by the edges to avoid fingerprints. Curl the plastic layer back and slip the front edge into Flextight's foil holder.

9. Lay the top layer of the holder down flat over the original.
 - For the reflective holder, note the four metal pegs (the top two are shown as **A** and **C** in the figure below); make sure that the clear plastic sheet is pressed all the way down over all four pegs. Note also the two curved tabs at the top of the holder (**B** in the figure below); the clear sheet must slip under each of these tabs, as shown.

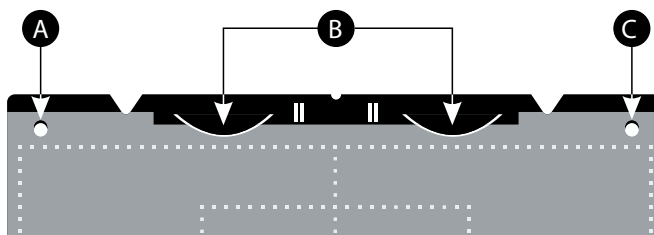

10. Go to your computer and follow the directions given in the FlexColor software manual to take a preview, make settings, and take the final scan. Alternatively you can press the scan button on the light table. This will initiate a 3F scan according to your 3F settings.

Resolutions

True Resolutions

The table below shows the max. resolutions (in ppi) available with each of the original holders when scanning in True Resolutions mode.

Original	Max. resolution (ppi) at full scanning width.
35 mm Portrait	8000 (Flextight X5) 6300 (Flextight X1)
35 mm Landscape	5000
45 x 60 mm Portrait	4000
60 x 60 - 60 x 70 mm	3200
4" x 5" Portrait	2040
A4 Portrait	960

Table 1: True Resolutions

Calibrating the scanner

The Flextight X5 scanner requires two types of calibration. The Flextight X1 only requires one:

- Both scanners require focus calibration. Focus calibration adjusts the positioning of the scanners' optics for each zoom level. If your scans appear unfocused or are slightly the wrong size, then you may need to make a new focus calibration to adjust the zoom mechanism. The focus calibration is stored in the scanners flash PROM, so it is retained when you move the scanner to a new computer. See **Focus Calibration** on page 12 for more information.
- White calibration is only required for reflective scans (it is done automatically for transparencies). During calibration, the scanner scans a white target to establish the white point along the full length of the scanners CCD. See **White Calibration for Reflectives** on page 13 for more information.

Both of the calibration procedures are simple and are initiated from the FlexColor program.

Focus calibration

The Flextight scanner uses an adjustable zoom and focus mechanism to optimize its scanning resolution for each of the original formats it can handle. If you suspect your scans are not as sharp as they should be, then you may need to calibrate your scanner. Note that you must not calibrate the scanner every day. It is intended that the scanner is calibrated not more than once every three months. In most cases, this procedure will never be necessary.

Use procedure below to make **Focus Calibration**:

1. Locate the Focus sheet that came with your scanner. It is a 8 x 9 cm (3" x 3.5") square of transparent black and white film.

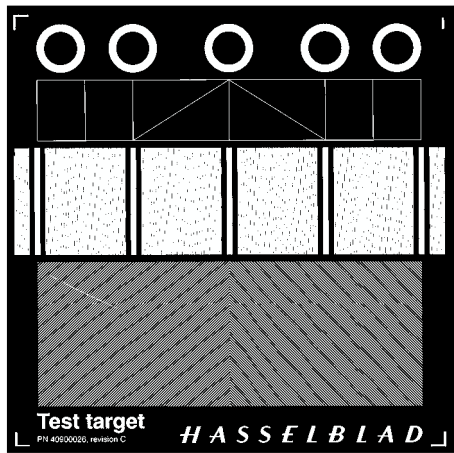

2. Mount the film into the 6 x 6 original holder with the text reading normally as shown. Place the sheet as straight as possible. Use the scanner's light table grid and the corners marked on the sheet to help align it.
3. Select **Focus Calibration** from the **Maintenance** menu.



4. Click on the **Calibrate** button, and the focus calibration starts.
5. When the focus calibration is finalized, you will get a message saying that the calibration was successful. Click OK..

The scanner is now calibrated for all resolutions and for both transparent and reflective originals.

White calibration for reflectives

The Flextight X5 scanner uses a white reference to make sure that all elements in the scanner's CCD react consistently to light brightnesses. The scanner has been calibrated at the factory, and the calibration data is stored in the scanner's flash PROM.

As the scanner ages, the properties of the light tubes may change slightly. Therefore, you must redo the white calibration every six months or so and immediately after changing the light tubes.

Use the procedure below to make a White Calibration:

1. Find the white calibration sheet that came with the scanner. It is a square white piece of paper (219 x 219 mm (8.6" x 8.6")). If you have lost the white calibration sheet, then you can use a flat (non-textured), perfectly white piece of paper of the same dimensions.
2. Your scanner came with several clear plastic layers for the reflective original holder. If you have used the reflective holder before, make sure that there are no finger prints or other marks on the plastic layer. Replace the layer with a new one if necessary.
3. Align the top edge of the sheet with the dotted line near the top of the original holder (see the figure below). Align each side of the target with the edges of the original holder.
4. Select **White Calibration** from the **Maintenance** window. The **External White Calibration** window appears.
5. Click on **Calibrate**. The scanner will take several scans of the white target and the whole process will take about eight minutes.

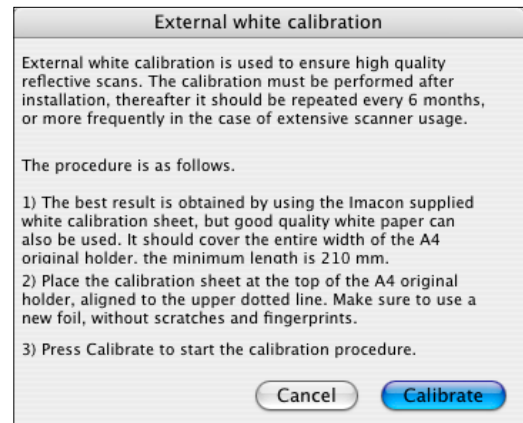
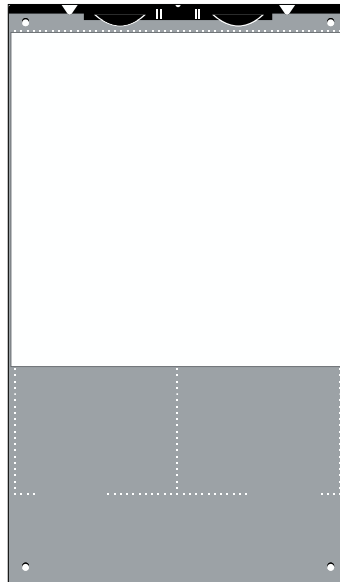

The light tubes

The Flextight X5 contains two light tubes: one for illuminating reflective originals from above, the other for shining light through transparencies from below. The Flextight X1 has only one light tube for transparency scanning.

NOTE! The two lamps are of different types and are not interchangeable.

Replacing the light tubes

If scans are suddenly coming out black (or all white if you are scanning negatives), then one of your light tubes may be defective. Make a preview using both types of scans (transparent and reflective) to find out which tube is affected.

- If transparencies are not working, then the bottom tube may be burned out.
- If reflectives are not working, then the top tube may be burned out.

Follow the procedure below to replace a tube:

(See Figure on next page)

1. Obtain the appropriate replacement lamp (ask your Flextight dealer).
2. Turn off and unplug the scanner from the primary power supply.
3. **IMPORTANT:** Let the light tubes cool down for approx. 10 minutes before proceeding.
3. Remove the two allen screws **A** (one in each side) using a 2.5 mm Allen key. Do not remove any other screws.
4. Press the back panel down (app. 5 mm) and lift out using the handle **B**
5. Turn the feed table to upright position.
6. Locate the tube to be replaced and dismount the plug **C**.
7. Remove the defective tube:
 - Press the flaps backwards to release the tube **E**.
 - Pull the tube gently out of the holders and then sideways out of the scanner.
8. If you are replacing the transparencies tube, you need to disassemble the tube from the sockets as well:
 - Remove the screw **F** to release the left socket **G**.
 - Remove the right socket **H** by simply pulling it off (you may need to use a small screwdriver to loosen this socket).
 - Assemble the new tube with the sockets.
9. Insert the replacement tube and mount it into the holders making sure that it is properly held in place by the flaps.
10. Connect the plug **C**.
11. **IMPORTANT:** The "T" on the lamp board cover **D** indicates the socket for the transparencies tube.
12. Lower the feed table **E**.
13. Mount the back panel and the two allen screws following the reverse of the procedure used when removing them.
14. Turn on the scanner and check function of the new tube.

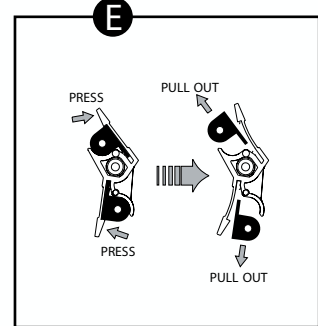
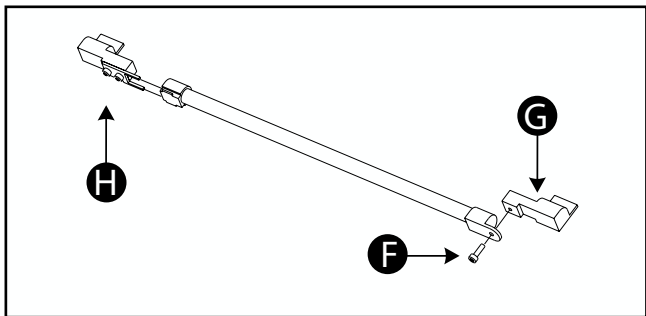
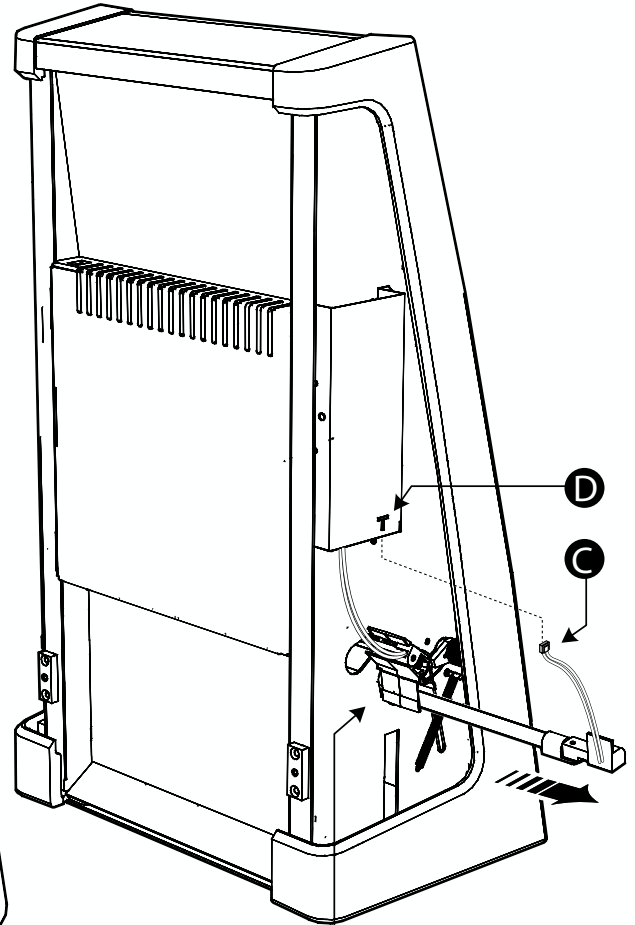
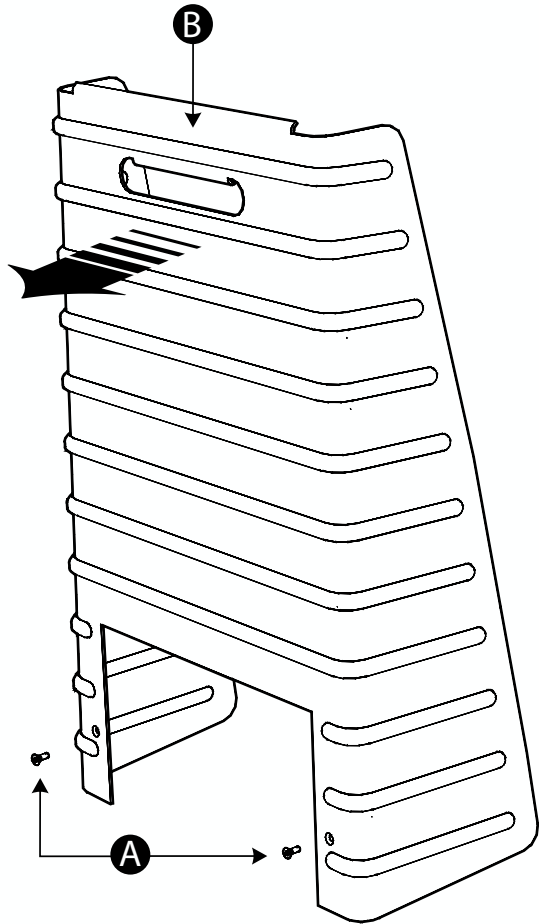

Cleaning the external surface of the scanner

The external surface of the scanner can be cleaned with a damp cloth. Be careful not to allow any moisture inside the scanner or on any of the connectors. Do not use alcohol or other solvents.

Disposal

If you need to dispose of the scanner, it must be delivered to an authorized waste plant for electronics equipment.

Technical specifications

Power Connector

Power Consumption

Max. 75 W during operation

Power Requirements

100-240V AC, 1.3 A, 50-60 Hz

Interface to Computer FireWire (IEEE 1394)

Front Panel

One multifunction switch (on/off switch)

Status indicator LED's

Drum Force 1 kg (2.2 lbs)

Operating Environment

Operating Temperature: 10 - 35 °C (50 - 95 °F)

Recommended Working Temperature: 10 - 25 °C (50 - 77 °F)

Humidity: 20 - 80 % RH (no condensation)

Storage Environment

Temperature: 0 - 50 °C (32 - 122 °F)

Relative humidity: 20 - 80 % RH (no condensation)

Originals

Transparencies: from 35 mm to 4 x 5 inches, < 1 mm thick

Reflectives: up to 220 x 310 mm (A4 oversize), < 1 mm thick (X5 only)

Standard 35 mm dias in frames (optional)

Lamp type

Reflectives Lamp (for Flextight X5): Part No. 10700022

Transparency lamp for Flextight X5: 10700032

Tranparency lamp for Flextight X1: 10700022

Dimensions

Height: 645 mm (25.4")

Width: 385 mm (15.2")

Depth: 220 mm (8.7") (feed table closed) 440 mm (17.3") (feed table open)

Weight: 20,5 kg (46 lbs)

FCC Notice

This equipment has been tested and found to comply with the limits for a Class A digital device, pursuant to Part 15 of the FCC Rules. These limits are designed to provide reasonable protection against harmful interference when the equipment is operated in a commercial environment. This equipment generates, uses, and can radiate radio frequency energy and, if not installed and used in accordance with the instruction manual, may cause harmful interference to radio communications. Operation of this equipment in a residential area is likely to cause harmful interference in which case the user will be required to correct the interference at their own expense.

HASSELBLAD

Declaration of conformity

Application of Council Directives: 89/336/EEC amended by 92/31/EEC,
93/68/EEC, 93/13/EEC,
73/23/EEC amended by 93/68/EEC.

Standards to which Conformity is declared:..... EN50081-2, EN50082-2, and
EN60950

Manufacturer:..... Hasselblad A/S
Hejrevej 30
DK-2400 Copenhagen NV
Denmark

Type of Equipment: Desktop CCD scanner

Model name: Flextight model X1

The undersigned, hereby declare that the equipment specified above conforms to the above Directives and Standards.

Place Copenhagen 2400 NV

Date..... November 7 th. 2006

Full name Tom Olesen

Position..... Managing Director



Signature

HASSELBLAD

Declaration of conformity

Application of Council Directives: 89/336/EEC amended by 92/31/EEC,
93/68/EEC, 93/13/EEC,
73/23/EEC amended by 93/68/EEC.

Standards to which Conformity is declared:..... EN50081-2, EN50082-2, and
EN60950

Manufacturer: Hasselblad A/S
Hejrevej 30
DK-2400 Copenhagen NV
Denmark

Type of Equipment: Desktop CCD scanner

Model name: Flextight model X5

The undersigned, hereby declare that the equipment specified above conforms to the above Directives and Standards.

Place Copenhagen 2400 NV

Date..... November 7 th. 2006

Full name Tom Olesen

Position..... Managing Director



Signature

© 2006 Hasselblad A/S. All rights reserved.

Flextight X1 / X5 User's Guide, Part No 75020123, revision 1.3

The information in this manual is furnished for informational use only, is subject to change without notice, and should not be construed as a commitment by Hasselblad A/S.

Hasselblad A/S assumes no responsibility or liability for any errors or inaccuracies that may appear in this manual. Hasselblad A/S assumes no responsibility or liability for loss or damage incurred during or as a result of using Hasselblad software or products.

Hasselblad, Imacon, FlexColor and Flextight are trademarks of Hasselblad A/S. Macintosh, Mac OS and FireWire are registered trademarks of Apple Computer, Inc.