



Installing a New Lamp Tutorial

To install a new lamp in your scanner, first remove the appropriate panel to expose the lamp. See the separate Tutorial on removing panels for instructions.

All the the scanners prior to the 848 model use a sleeve over the bulbs to concentrate the light and project the light to the CCD.

The very first Precision scanners produced did not have a sleeve over the bulbs but performance will be improved by adding a sleeve.

Do not throw away any sleeves you may have. When replacing a lamp, save the old sleeve to reuse. Note, some sleeves were glued to the lamps at the factory. These can be removed by carefully breaking the bond of the adhesive.

The sleeves appear to be manufactured from aluminum tubing with machined slots to allow to light to be directed where needed. They are probably laser cut. If you have access to the right equipment, you could make one from the proper sized tubing.

A more practical solution for a missing tube comes from Arye Rubenstein, a frequent contributor to the Imacon Users Group on Yahoo Groups. He suggests applying aluminum tape and cutting new windows with an Exacto knife. This tape is sold as a duct tape for heating pipes. Not to be confused with ordinary duct tape. It is metallic silver.

Precision Scanners. Lets begin with the Precision series of scanners. There are two lamps in the scanner. One for transmissive scans and illuminating the light table and the other for reflective scanning. The bulbs are the same but the sleeves are different. The bulbs used are an Osram L 8W/12-950 Lumilux De Luxe Daylight (5400K). Decoded that is an 8 watt bye-pin 12" long, daylight color temperature bulb. It is my understanding that Osram no longer manufactures this bulb but other companies make a bulb that works. Look for 8 watts and daylight color tem-

perature.

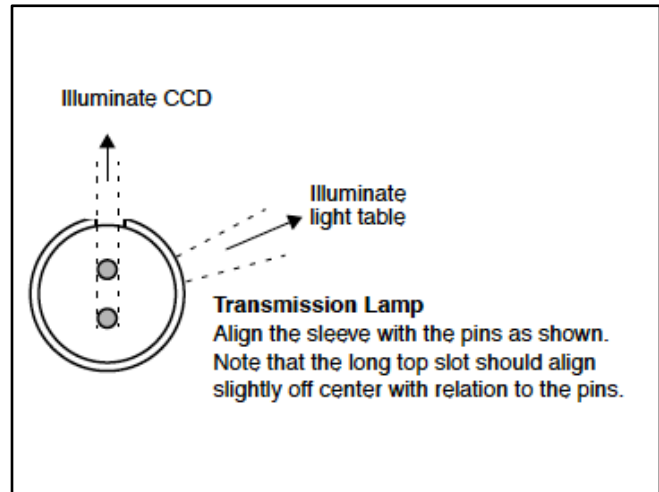

Here is the correct positioning for the transmissive light sleeve. This is a starting point for the sleeve, we will discuss how to fine tune it later.

Here is the reflective sleeve positioning. It is less critical than the transmissive sleeve.

If your transmissive bulb goes out you can replace it with the reflective bulb. Just be sure to change the sleeve.

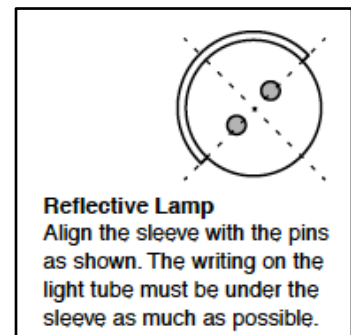

Once you have removed the side panels, you can rotate the bulb 90 degrees to remove it from the sockets. Carefully guide it out of the machine. Newer models use sockets that allow the tubes to be rotated all the way around, but that click into position at each quarter turn. The lamp is locked in place in all but one of these four positions, so you may need to try up to three positions before the lamp comes free. When inserting the new bulb, rotate it till it locks into place. You can usually feel it snap to.

For maximum performance with the transmissive bulb you can fine tune the sleeve position to get the maximum amount of light striking the CCD. After inserting the new bulb, remove the top cabinet.

Start up the scanner and insert a 4 x 5 film holder. Select a transmissive setup. Make a 4 x 5 preview, this will position the CCD. Remove the front cover. This will expose the lens and CCD. Push the holder into the scanner enough to allow the light to shine through it. A couple of inches is fine.

Push the left end of the Lens and CCD against the back of the scanner. The front cover holds them in position normally. You should see the light shining on the CCD. Carefully rotate the sleeve on the bulb until the maximum amount of light strikes the CCD. Do not turn the bulb, just the sleeve. If you have trouble determining the best position, rotate the sleeve away from you until the light begins to fall off. Then rotate it towards you until the light begins to fall off. Note both positions. Turn it halfway in between, that should be the maximum light.

Use a small piece of tape to attach the sleeve to the bulb so it will not rotate. If you have trouble working through the side panels, you can carefully lay the scanner on its back and remove the bottom panel and access the bulb that way. Reinstall all the panels and scan away.

Photo Scanners. For the Photo model scanner the access is through the bottom panel. The bulb is an OSRAM L 6W/12-950 Lumilux De Luxe Daylight (5400K). It is the same as the Precision except it is 6 watts. I think you could use the 8 watt bulb with no problems but I have not tested this.

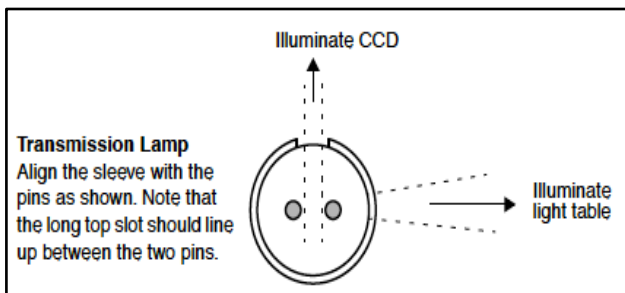

Here is the alignment for the Photo sleeve. It is a different sleeve than the Precision. Fine tuning is usually not required.

848 Scanner. To remove the lamp tubes first remove the front panel and the side panels. Be sure to let the bulbs cool down before touching them, they get quite hot. Here is a diagram of how the bulb come out.

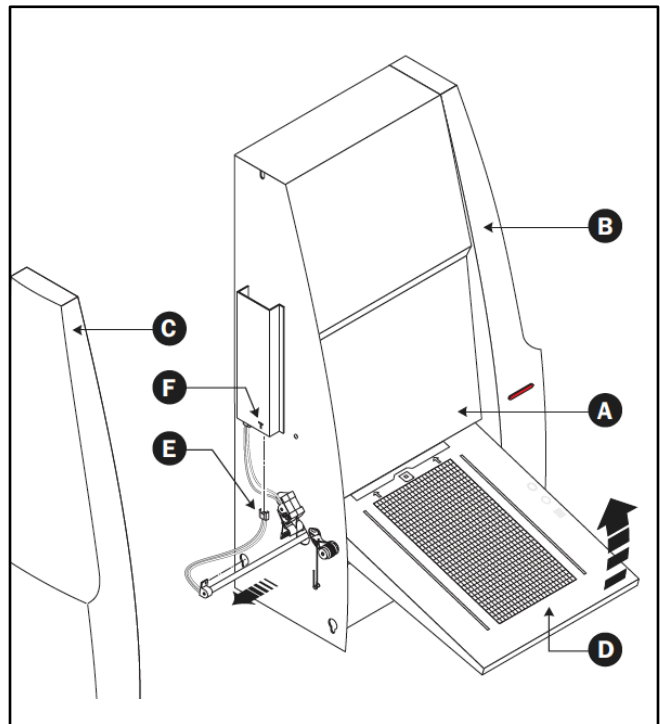

The bulbs are held in place by clips. Press back the flap and gently remove the bulb. There are no sleeves on the bulb.

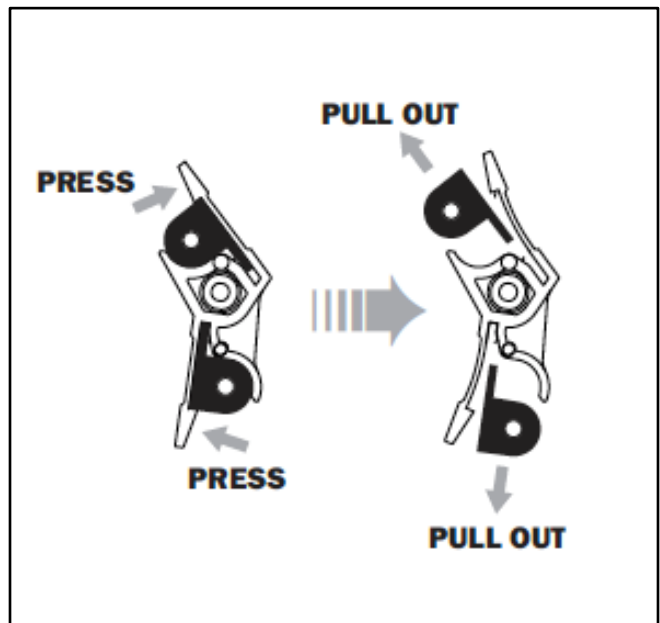

If you like this tutorial, please make a donation to help offset the cost of producing it. You can donate to my PayPal account at www.paypal.com. Click on Send and fill in gyaeger@cox.net. Enter the amount and click continue.

Thank you for your support.

Copyright 2015 Gerry Yaeger, The Digital Coach.